

# CHECK 515Y

## HORIZONTAL SWING – BRONZE

150 lb. SWP-300 lb. WOG† • Industrial Service  
• Bronze Disc • Threaded Ends

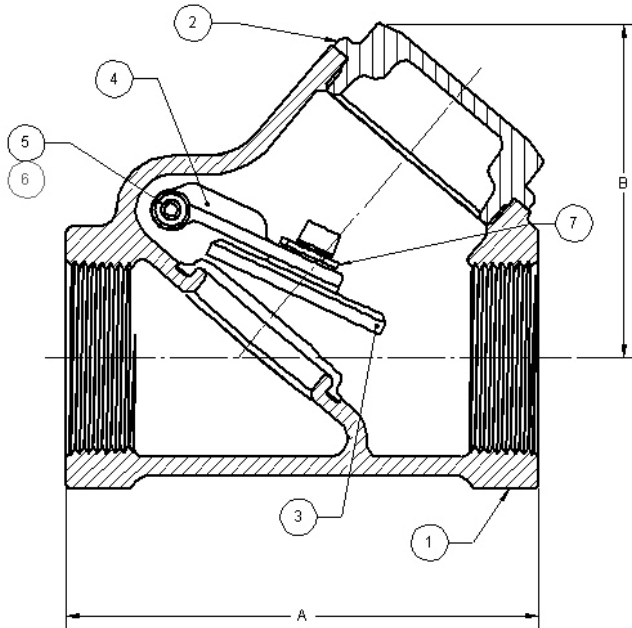

### SPECIFICATIONS

<b>515Y</b>	<b>Conforms to: MSS SP-80. Type 3, Class 150, Threaded Ends.</b>
-------------	--

### MATERIAL LIST

NO	PART	MATERIAL	SPECIFICATION
1	Body	Cast Bronze	ASTM B62
2	Cap	Brass (1/4" – 3/8")	ASTM B16
		Cast Bronze (1/2" and Larger)	ASTM B62
3	Disc	Brass (1/4" - 3/8")	ASTM B505
		Brass (1/2" – 1-1/2")	ASTM B453
		Cast Bronze (2")	ASTM B62
4	Lever	Silicon Bronze	ASTM B584
5	Pin	Stainless Steel	TYPE 303
6	Plug (not shown)	Brass	ASTM B16
7	Ring	Stainless Steel	TYPE 304

### DIMENSIONS - INCHES / MILLIMETERS

Units	Size	A	B	C <sub>v</sub>
Inches	1/4	2.13	1.44	3.3
mm	6.35	53.98	36.53	3.3
Inches	3/8	2.13	1.44	6.0
mm	9.53	53.98	36.53	6.0
Inches	1/2	2.31	1.44	10.0
mm	12.70	58.75	36.53	10.0
Inches	3/4	2.63	1.69	18.0
mm	19.05	66.68	42.88	18.0
Inches	1	3.25	2.00	31.0
mm	25.40	82.55	50.80	31.0
Inches	1 1/4	3.56	2.13	54.0
mm	31.75	90.50	53.98	54.0
Inches	1 1/2	4.00	2.38	76.0
mm	38.10	101.60	60.33	76.0
Inches	2	4.75	2.81	131.0
mm	50.80	130.18	207.98	131.0

† Non-Shock

*BETTER AT EVERY TURN*

The information presented on this sheet is correct at the time of publication. Hammond Valve reserves the right to change design, and/or material specifications without notice. For the Installation, Operation and Maintenance Manual (IOM) see the engineering section on our website. For the most current information access [www.hammondvalve.com](http://www.hammondvalve.com) Hammond Valve is a registered trade mark of Milwaukee Valve Company.



**HAMMONDVALVE**  
[www.hammondvalve.com](http://www.hammondvalve.com)