

# BRASS SWING CHECK VALVE

## UP967 & UP968

200 WOG  
Designed in accordance with the requirements of California AB 1953  
and Vermont S 152



WQA tested and Certified against WQA ORD0902 for California "lead free" compliance.

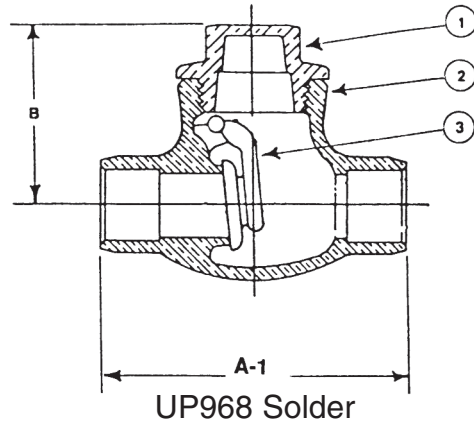
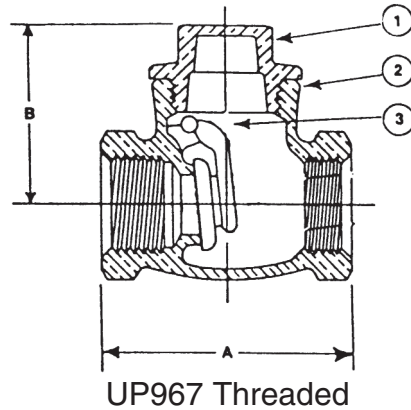

### RATING

- 200 LB POTABLE WATER SERVICE

**Warning: DO NOT USE**  
for reciprocating air compressor service.

### FEATURES

- BRASS BODY
- THREADED OR SOLDER ENDS
- THREADED BONNET
- INTEGRAL SEAT
- BRASS DISC
- 100% FACTORY TESTED
- INTERNATIONAL

DIMENSIONS (INCHES)				Approx. Weight 967	Approx. Weight 968	C <sub>v</sub>
SIZE	A	A-1	B			
1/2	2.13	2.53	1.53	0.44	0.45	10
3/4	2.31	3.13	1.63	0.57	0.62	18
1	2.72	3.91	1.78	0.89	0.97	31
1 1/4	3.13	4.44	2.00	1.28	1.42	54
1 1/2	3.50	5.00	2.25	1.72	1.84	76
2	4.28	6.13	2.69	2.58	2.75	131

MATERIAL SPECIFICATION			
1	Cap	Cast Brass	ASTM B283 C69300
2	Body	Cast Brass	ASTM B283 C69300
3	Disc	Cast Brass	ASTM B283 C69300

Rev. 4

Hammond Valve  
16550 W. Stratton Drive  
New Berlin, WI 53151  
Phone: 262-432-2702  
Fax: 262-432-2703

**Note:** Lead free refers to the wetted surface of the pipe, fittings and fixtures in potable water systems that have a weighted average lead content 0.25%. Source: California Health and Safety Code (116875).

The information presented on this sheet is correct at the time of publication. Hammond Valve reserves the right to change design, and/or material specifications without notice. For the Installation, Operation and Maintenance Manual (IOM) see the engineering section on our website. For the most current information access [www.hammondvalve.com](http://www.hammondvalve.com)  
Hammond Valve is a registered trade mark of Milwaukee Valve Company.