

5100-HI Series 2"-12"

**Iron Butterfly Valve
Wafer Style
200 psi Non-Shock WOG
Specifications: API-609 MSS SP-67 Type 1**

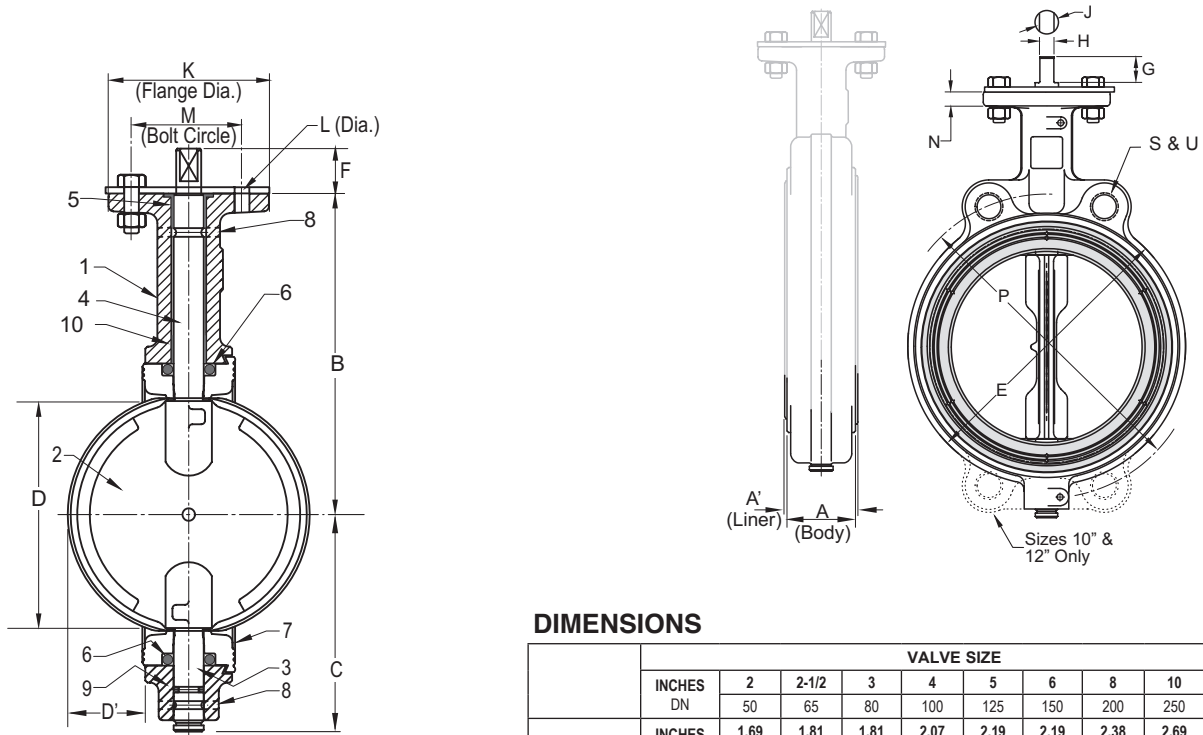

DIMENSIONS

	VALVE SIZE									
	INCHES DN	2	2-1/2	3	4	5	6	8	10	12
A (Body)	INCHES	1.69	1.81	1.81	2.07	2.19	2.19	2.38	2.69	3.06
	mm	43	46	46	52	55	55	60	68	78
A ¹ (Liner)	INCHES	1.82	1.94	1.94	2.20	2.32	2.32	2.51	2.82	3.21
	mm	46	49	49	55	58	58	63	71	82
B	INCHES	5.50	6.00	6.25	7.00	7.53	8.00	9.38	10.56	12.06
	mm	139	152	158	177	191	203	238	268	306
C	INCHES	3.06	3.31	3.75	4.25	4.94	5.56	5.56	7.88	9.25
	mm	77	84	95	108	125	141	166	200	235
D (Chord Dia)	INCHES	1.49	2.01	2.64	3.67	4.71	5.66	7.72	9.70	11.68
	mm	37	51	67	93	119	143	196	246	296
D ¹ (Intrusion)	INCHES	0.28	0.44	0.69	1.06	1.50	1.94	2.84	3.69	4.50
	mm	7	11	17	27	38	49	72	93	114
E	INCHES	4.13	4.88	5.38	6.88	7.75	8.75	11.00	13.38	16.13
	mm	105	124	137	175	197	222	279	340	410
F	INCHES	1.13	1.13	1.13	1.13	1.13	1.13	1.50	1.50	1.50
	mm	28	28	28	28	28	28	38	38	38
G	INCHES	0.81	0.81	0.81	0.81	0.81	0.81	1.06	1.06	1.06
	mm	20	20	20	20	20	20	27	27	27
H	INCHES	0.35	0.35	0.35	0.40	0.40	0.44	0.53	0.71	0.71
	mm	8	8	8	10	10	11	13	18	18
J	INCHES	0.50	0.50	0.50	0.56	0.56	0.62	0.75	1.00	1.00
	mm	12	12	12	14	14	14	19	25	25
K		4	4	4	4	4	4	6	6	6
L (Dia)	INCHES	0.44	0.44	0.44	0.44	0.44	0.44	0.56	0.56	0.56
	mm	11	11	11	11	11	11	14	14	14
M	INCHES	3.25	3.25	3.25	3.25	3.25	3.25	5.00	5.00	5.00
	mm	82	82	82	82	82	82	127	127	127
N	INCHES	0.44	0.44	0.44	0.44	0.44	0.44	0.50	0.50	0.50
	mm	11	11	11	11	11	11	12	12	12
P	INCHES	4.75	5.50	6.00	7.50	8.50	9.50	11.75	14.25	17.00
	mm	120	139	152	190	215	241	298	362	431
R	Flange Bolt Size	5/8-11	5/8-11	5/8-11	5/8-11	3/4-10	3/4-10	3/4-10	7/8-9	7/8-9
S	No. of Holes	2	2	2	2	2	2	2	4	4
U (Hole Dia)	INCHES	0.75	0.75	0.75	0.75	0.88	0.88	0.88	1.00	1.00
	mm	19	19	19	19	22	22	22	25	25

MATERIALS LIST

ITEM	PART	MATERIALS
1	BODY	CAST IRON ASTM A126 CL.B
2	DISC	ALUMINUM BRONZE ASTM B148
3	BOTTOM STEM	STAINLESS STEEL TYPE 416
4	TOP STEM	STAINLESS STEEL TYPE 416
5	TOP BEARING	REINFORCED NYLON
6	SEAL	EPDM
7	LINER	EPDM
8	ROLL PIN	STAINLESS STEEL
9	STEM SEAL	EPDM
10	LOWER BEARING	REINFORCED NYLON
11	OPERATOR	LEVER HANDLE
		GEAR OPERATOR

Note: The wetted surface of this product (In any material combination.) contacted by consumable water contains less than one quarter of one percent (.25%) of lead by weight.

The information presented on this sheet is correct at time of publication. Hammond Valve reserves the right to change design and/or materials without notice. For our Installation, Operation and Maintenance Manual and the most current product information go to www.hammondvalve.com. Hammond Valve is a registered trademark of Milwaukee Valve.

⚠ State of California Prop 65 **WARNING:** Cancer and Reproductive Harm. For more information visit www.p65warnings.ca.gov.



6	2	1	1	01
SERIES	BODY DESCRIPTION / MATERIAL	DISC & STEM MATERIAL DESCRIPTION	LINER MATERIAL	OPTIONS
6 - 6000 SERIES 5 - 5000 SERIES	1 - WAFER / IRON (ASTM A126B)* 2 - LUG / IRON (ASTM A126B)* 3 - WAFER / DUCTILE (ASTM A536) 4 - LUG / DUCTILE (ASTM A536) 8 - WAFER / DUCTILE EPOXY COATED 9 - LUG / DUCTILE EPOXY COATED	0 - NICKEL PLATED DUCTILE IRON / 416 S.S. 1 - ALUMINUM/BRONZE (ASTM B148) / 416 S.S. 2 - 316 S.S. / 316 S.S. 3 - ALUMINUM/BRONZE (ASTM B148) / 316 S.S. 4 - NICKEL PLATED DUCTILE IRON / 316 S.S. 5 - EPOXY COATED IRON 6 - NYLON COATED IRON	0 - BUNA - N 1 - EPDM 3 - VITON 5 - BLACK NEOPRENE 6 - WHITE NEOPRENE 7 - HYPALON 8 - TEFLON OVER BUNA	00 - BARE STEM 01 - 10 POSITION LEVER LOCK 02 - 10 POSITION LEVER W/ MEMORY STOP 03 - GEAR OPERATOR W/ HANDWHEEL

* 5000 SERIES IS ONLY AVAILABLE IN CAST IRON WAFER OR LUG BODY WITH ALUMINUM BRONZE DISC, EPDM LINER, LEVER OR GEAR OPERATOR.

*HAMMOND VALVE RESERVES THE RIGHT TO UPGRADE TO DUCTILE IRON BODIES WITHOUT NOTICE AND WITHOUT ADDITIONAL COST.

BUTTERFLY FEATURES & OPTIONS

STANDARD FEATURES

HEAVY DUTY DESIGN
 PHENOLIC CARTRIDGE DESIGN
 LOW TORQUE LINER
 BUBBLE TIGHT SHUT OFF
 LOW TORQUE POLYMER BEARING STD
 DEAD END SERVICE (LUG ONLY)
 FIELD REPAIRABLE

EXTENDED NECK BODY
 LOW PROFILE DISC
 BLOWOUT PROOF STEMS
 STAINLESS STEEL STEMS (416)
 BI-DIRECTIONAL SHUT OFF (EXCEPT AS NOTED)
 VACUUM RATINGS TO 29" OF MERCURY

OPERATORS

MANUAL

10 POSITION, PAD LOCKABLE, DUCTILE IRON LEVER HANDLE –STD, EPOXY COATING OPTIONAL.

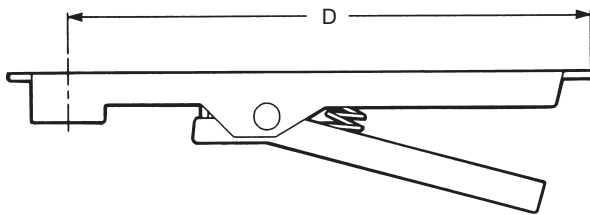

VALVE SIZE	PART NUMBER	D-DIMENSION (inches)
2, 2-1/2, 3	84016-LL	9.00
4, 5	84016-RL	11.00
6	84016-SL	11.00
8	84016-UL	15.00
10, 12	84016-WL	15.00

WEATHER RESISTENT GEAR OPERATOR, CAST IRON, MEMORY STOP AND LOCKING DEVICE OPTIONAL.

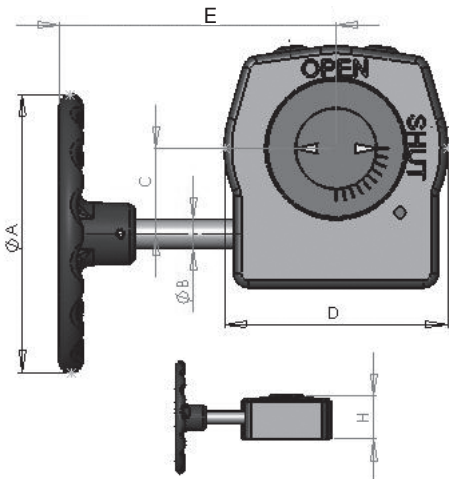

VALVE SIZE	PART NUMBER	GEAR RATIO	ØA	ØB	C	D	E	H
2-3	8115-24N-L	24:1	6.00	0.63	1.80	4.20	8.80	2.30
4-5	8115-24N-R	24:1	6.00	0.63	1.80	4.20	8.80	2.30
6	8115-24N-S	24:1	6.00	0.63	1.80	4.20	8.80	2.30
8	8115-30N-U	30:1	9.00	0.75	2.60	6.03	8.50	3.23
10-12	8115-30N-W	30:1	9.00	0.75	2.60	6.03	8.50	3.23
14-16	8115-48N-16	50:1	12.00	0.75	3.10	6.97	13.40	3.46
18-20	8115-65N-20	80:1	12.00	1.00	4.93	10.30	12.60	4.63
24	8115-78N-24	120:1	16.00	1.00	4.93	10.30	12.60	6.00

ACTUATORS

PNEUMATIC ACTUATORS
 DOUBLE ACTING ACTUATORS
 SPRING-RETURN ACTUATORS
 SOLENOID VALVES
 LIMIT SWITCHES
 VALVE POSITIONERS

120 VOLT AC AND DC VOLTAGES
 NEMA 4 AND 7 HOUSING
 4-20 mA DC VALVE POSITIONERS
 ACTUATOR BRACKETS
 EXTRA LIMIT SWITCHES
 ELECTRIC ACTUATORS

The information presented on this sheet is correct at time of publication. Hammond Valve reserves the right to change design and/or materials without notice. For our Installation, Operation and Maintenance Manual and the most current product information go to www.hammondvalve.com. Hammond Valve is a registered trademark of Milwaukee Valve.

⚠ State of California Prop 65 **WARNING:** Cancer and Reproductive Harm. For more information visit www.p65warnings.ca.gov.

OPTIONS & ACCESSORIES

MEMORY STOP

The Memory Stop provides an adjustable stop when the valve is used in a balancing application. The Memory Stop can be set to any preset opening point.

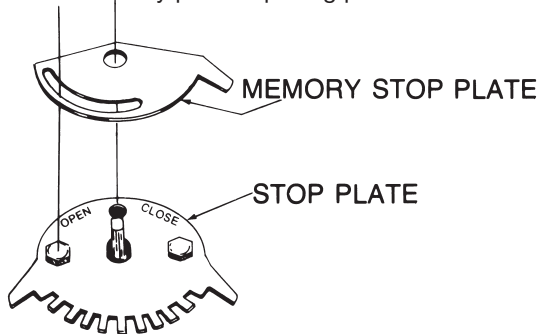

STEM EXTENSION

Provides means of operation at a required distance away from the valve body. Manual or automatic, actuators are easily adapted to mounting flange on the extension. To order, specify distance from valve mounting-flange to base of operator.

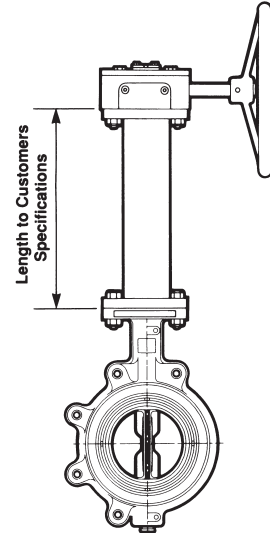

CHAINWHEEL

The chain wheel provides for remote operation of the valve in high, normally out-of-reach locations. Attaches to the gear operator easily for quick valve open/close response. Sprocket rim is aluminum; chain is steel. Specify the handwheel diameter ("A" dimension) and chain length. Chain sold separately.

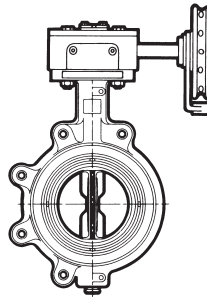

The information presented on this sheet is correct at time of publication. Hammond Valve reserves the right to change design and/or materials without notice. For our Installation, Operation and Maintenance Manual and the most current product information go to www.hammondvalve.com. Hammond Valve is a registered trademark of Milwaukee Valve.

⚠ State of California Prop 65 **WARNING:** Cancer and Reproductive Harm. For more information visit www.p65warnings.ca.gov.

Butterfly Height With Lever or Gear Operator Wafer and Lug Styles

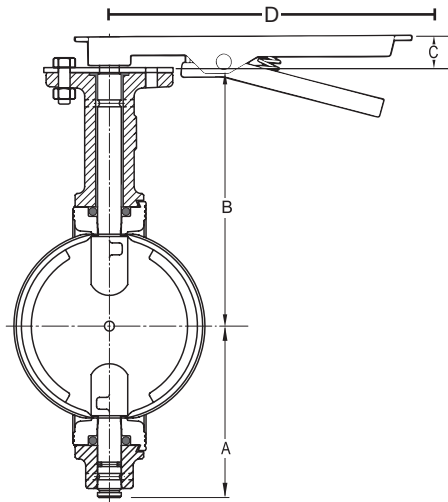

2"-12"

Butterfly with Lever Handle						
Size		A	B	C	D	Height
2"	INCHES	3.06	5.50	1.13	9.00	9.69
2 1/2"	INCHES	3.31	6.00	1.13	9.00	10.44
3"	INCHES	3.75	6.25	1.13	9.00	11.13
4"	INCHES	4.25	7.00	1.13	11.00	12.38
5"	INCHES	4.94	7.53	1.13	11.00	13.60
6"	INCHES	5.56	8.00	1.13	11.00	14.69
8"	INCHES	5.56	9.38	1.50	15.00	16.44
10"	INCHES	7.88	10.56	1.50	15.00	19.94
12"	INCHES	9.25	12.06	1.50	15.00	22.81

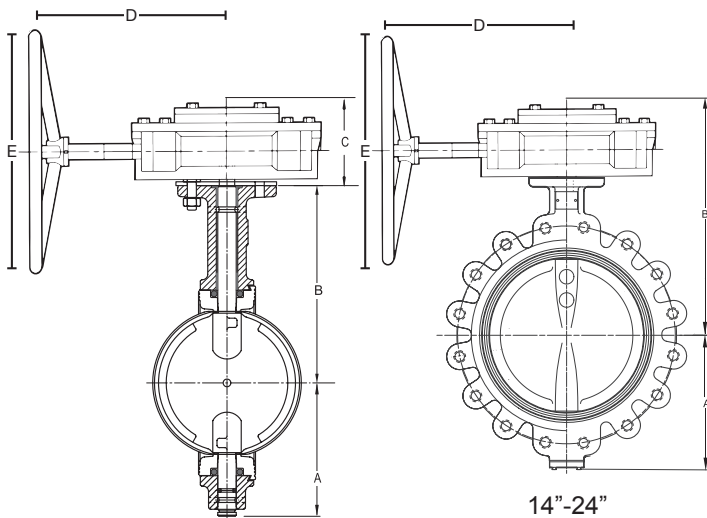

2"-12"

14"-24"

Butterfly with Gear Operator							
Size		A	B	C	D	E	Height
2"	INCHES	3.06	5.50	2.30	8.80	6.00	10.86
2 1/2"	INCHES	3.31	6.00	2.30	8.80	6.00	11.61
3"	INCHES	3.75	6.25	2.30	8.80	6.00	12.30
4"	INCHES	4.25	7.00	2.30	8.80	6.00	13.55
5"	INCHES	4.94	7.53	2.30	8.80	6.00	14.77
6"	INCHES	5.56	8.00	2.30	8.80	6.00	15.86
8"	INCHES	5.56	9.38	3.23	8.50	9.00	18.17
10"	INCHES	7.88	10.56	3.23	8.50	9.00	21.67
12"	INCHES	9.25	12.06	3.23	8.50	9.00	24.54
14"	INCHES	11.56	17.25	-	13.40	12.00	28.81
16"	INCHES	12.69	18.75	-	13.40	12.00	31.44
18"	INCHES	13.63	19.63	-	12.60	12.00	33.26
20"	INCHES	15.13	20.88	-	12.60	12.00	36.01
24"	INCHES	18.06	25.00	-	12.60	16.00	43.06

Note: 30"-48" Please see specification sheet.

The information presented on this sheet is correct at time of publication. Hammond Valve reserves the right to change design and/or materials without notice. For our Installation, Operation and Maintenance Manual and the most current product information go to www.hammondvalve.com. Hammond Valve is a registered trademark of Milwaukee Valve.

⚠ State of California Prop 65 **WARNING:** Cancer and Reproductive Harm. For more information visit www.p65warnings.ca.gov.