



6411-00/6411-03 14"-24"



Tested and Certified by IAPMO R&T to NSF/ANSI 372 and NSF/ANSI 61

Iron Butterfly Valve for Potable Water
LUG Style
150 psi Non-Shock WOG
Dead End Service to 150 psi Max*
Specifications: MSS SP-67 Type 1

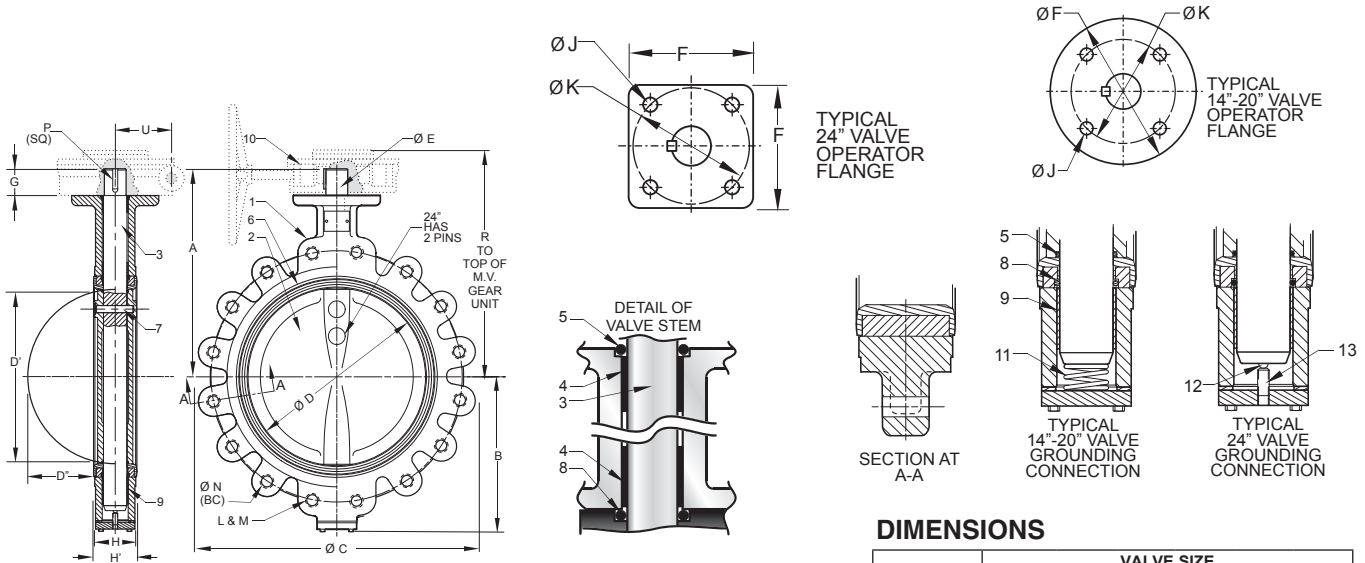

MATERIALS LIST

ITEM	PART	MATERIALS
1	BODY	DUCTILE IRON ASTM A536
2	DISC	ALUMINUM BRONZE ASTM B148
3	STEM	STAINLESS STEEL TYPE 416
4	TOP BEARING	REINFORCED NYLON
5	STEM O-RING	EPDM
6	LINER	EPDM
7	STEM PIN	ANSI 4140 OR AISI 6150
8	LINER O-RING	EPDM
9	LOWER BEARING	REINFORCED NYLON
10	OPERATOR	GEAR OPERATOR GEAR OPERATOR WITH MEMORY STOP GEAR OPERATOR WITH LOCK ACTUATOR-AIR/AIR (1) ACTUATOR-AIR/SPRING (1) ACTUATOR-ELECTRIC (1)
11 14"-20"	GROUNDING SPRING	STAINLESS STEEL TYPE 302
12 24" Only	GROUNDING BALL	AISI-1022
13 24" Only	TENSION SCREW	AISI-1020

(1)- Consult Automation Department.
 * Uni-directional

DIMENSIONS

	VALVE SIZE					
	INCHES DN	14	16	18	20	24
A	INCHES	15.50	16.75	18.50	19.75	22.43
	mm	398	425	469	501	569
B	INCHES	11.56	12.69	13.63	15.13	18.06
	mm	258	322	346	384	458
C	INCHES	21.00	23.50	25.00	27.50	32.10
	mm	533	596	635	698	815
D	INCHES	13.25	15.25	17.24	19.24	23.25
	mm	336	387	438	489	591
D ¹ (Chord Dia.)	INCHES	12.94	14.77	16.70	18.64	22.49
	mm	329	375	424	474	571
D ¹¹ (Intrusion)	INCHES	5.06	5.59	6.34	7.09	8.55
	mm	128	142	161	180	217
E	INCHES	1.63	1.63	2.13	2.13	2.13
	mm	41	41	54	54	54
F	INCHES	6.50	6.50	9.50	9.50	7.50
	mm	165	165	241	241	190
G	INCHES	2.00	2.00	3.00	3.00	3.06
	mm	50	50	76	76	77
H (Body)	INCHES	3.06	4.00	4.50	5.00	6.06
	mm	77	101	114	127	153
H ¹ (Liner)	INCHES	3.19	4.13	4.63	5.13	6.19
	mm	81	104	117	130	157
J	INCHES	0.69	0.69	0.81	0.81	0.81
	mm	17	17	20	20	20
K	INCHES	5.25	5.25	7.50	7.50	7.50
	mm	133	133	190	190	190
L	No. of Holes	12	16	16	20	20
M	Thread Size	1-8	1-8	1 1/8-7	1 1/8-7	1 1/4-7
N	INCHES	18.75	21.25	22.75	25.00	29.50
	mm	476	540	577	635	749
P (Key Size)	INCHES	0.38	0.38	0.50	0.50	0.50
	mm	9	9	12	12	12
R	INCHES	17.25	18.75	19.63	20.88	25.00
	mm	438	475	458	530	635
U	INCHES	3.13	3.13	4.50	4.50	4.63
	mm	79	79	114	114	117

Note: Lead free refers to the wetted surface of the pipe, fittings and fixtures in potable water systems that have a weighted average lead content ≤ 0.25%. Source: California Health and Safety Code (116875).

The information presented on this sheet is correct at time of publication. Hammond Valve reserves the right to change design and/or materials without notice. For our Installation, Operation and Maintenance Manual and the most current product information go to www.hammondvalve.com. Hammond Valve is a registered trademark of Milwaukee Valve.

⚠ State of California Prop 65 **WARNING:** Cancer and Reproductive Harm. For more information visit www.p65warnings.ca.gov.



6	2	1	1	01
SERIES	BODY DESCRIPTION / MATERIAL	DISC & STEM MATERIAL DESCRIPTION	LINER MATERIAL	OPTIONS
6 - 6000 SERIES 5 - 5000 SERIES	1 - WAFER / IRON (ASTM A126B)* 2 - LUG / IRON (ASTM A126B)* 3 - WAFER / DUCTILE (ASTM A536) 4 - LUG / DUCTILE (ASTM A536) 8 - WAFER / DUCTILE EPOXY COATED 9 - LUG / DUCTILE EPOXY COATED	0 - NICKEL PLATED DUCTILE IRON / 416 S.S. 1 - ALUMINUM/BRONZE (ASTM B148) / 416 S.S. 2 - 316 S.S. / 316 S.S. 3 - ALUMINUM/BRONZE (ASTM B148) / 316 S.S. 4 - NICKEL PLATED DUCTILE IRON / 316 S.S. 5 - EPOXY COATED IRON 6 - NYLON COATED IRON	0 - BUNA - N 1 - EPDM 3 - VITON 5 - BLACK NEOPRENE 6 - WHITE NEOPRENE 7 - HYPALON 8 - TEFLON OVER BUNA	00 - BARE STEM 01 - 10 POSITION LEVER LOCK 02 - 10 POSITION LEVER W/ MEMORY STOP 03 - GEAR OPERATOR W/ HANDWHEEL

* 5000 SERIES IS ONLY AVAILABLE IN CAST IRON WAFER OR LUG BODY WITH ALUMINUM BRONZE DISC, EPDM LINER, LEVER OR GEAR OPERATOR.

*HAMMOND VALVE RESERVES THE RIGHT TO UPGRADE TO DUCTILE IRON BODIES WITHOUT NOTICE AND WITHOUT ADDITIONAL COST.