

509Y P2 1/2"-2"

ULTRAPRESS®

Bronze Check Valve
200 psig @ 250°F †
Horizontal Swing • Press Ends
Y-Pattern
Conforms to: MSS SP-80

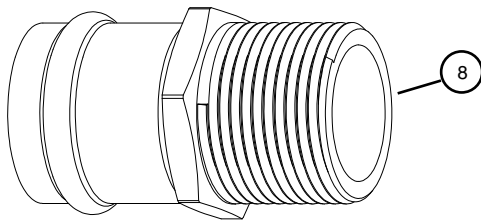
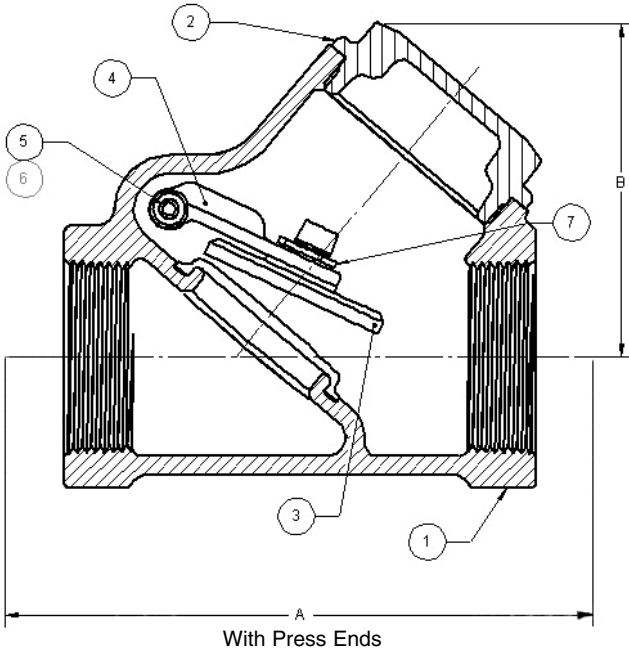

Press End Adapter (4151 Series)

Note: Not intended for use in potable water.

MATERIAL LIST			
No.	PART	MATERIAL	SPECIFICATION
1	Body	Cast Bronze	ASTM B62
2	Cap	Cast Bronze (1/2" and Larger)	ASTM B62
3	Disc	Brass (1/2"- 1-1/2") Cast Bronze (2")	ASTM B453 ASTM B62
4	Lever	Silicon Bronze	ASTM B584
5	Pin	St. Steel	TYPE 303
6	Plug (not shown)	Brass	ASTM B16
7	Retaining Ring	St. Steel	TYPE 304
8	Press Adapters	Brass Fitting W/EPDM O-Ring	ASTM B283 C27450

DIMENSIONS - INCHES/MILLIMETERS					
Units	Size	STD Insertion Depth	A	B	C _v
Inches mm	1/2	0.87 22	5.63 143	1.75 45	7.2
Inches mm	3/4	0.98 25	6.58 167	1.94 49	13.0
Inches mm	1	0.98 25	7.69 195	2.50 64	22.0
Inches mm	1 1/4	1.02 26	8.45 215	3.00 76	39.0
Inches mm	1 1/2	1.42 36	9.11 231	3.31 84	56.0
Inches mm	2	1.58 40	11.88 302	4.00 101	92.0

† Non-Shock

INNOVATION IN EVERY VALVE

The information presented on this sheet is correct at time of publication. Milwaukee Valve reserves the right to change design and/or materials without notice. For our Installation, Operation and Maintenance Manual and the most current product information go to www.milwaukeevalve.com. ⚠ State of California Prop 65
WARNING: Cancer and Reproductive Harm. For more information visit www.p65warnings.ca.gov.



MILWAUKEE VALVE