

8604/8603* P2 1/2"-2"

Bronze Ball Valve
Three Piece
Full Port
200 psig @ 250°Ft
Press x Press Ends
Press x Threaded Ends Available (Consult Factory)
Blow-Out Proof Stem
Conforms to MSS SP-110



***Not intended for use in potable water.**

MATERIAL LIST

ITEM	PART	MATERIAL	ASTM SPEC
1	Body	Bronze	B584
2	End Cap	Bronze	B584
3	Stem	Brass	B16
		316 Stainless Steel (1)	A276
4	Packing Nut	Brass	B16
5	Packing	PTFE	
6	Thrust Washer	RPTFE, 25% Glass Filled	
7	Ball	CP Brass	B283
		316 Stainless Steel (1)	A276
8	Seat	RPTFE, 15% Glass Filled	
9	O'Ring	Viton	Commercial
10	Handle	Steel w/Zinc Plating	Commercial
11	Hand Grip	Vinyl	Commercial
12	Handle Nut	Steel w/Zinc Plating	Commercial
13	Bolt	Steel w/Zinc Plating	Commercial
14	Nut	Steel w/Zinc Plating	Commercial
15	Press Adapters	Brass Fitting w/EPDM O-Ring	B283

(1) Ball & Stem are stainless steel for 8603 P2

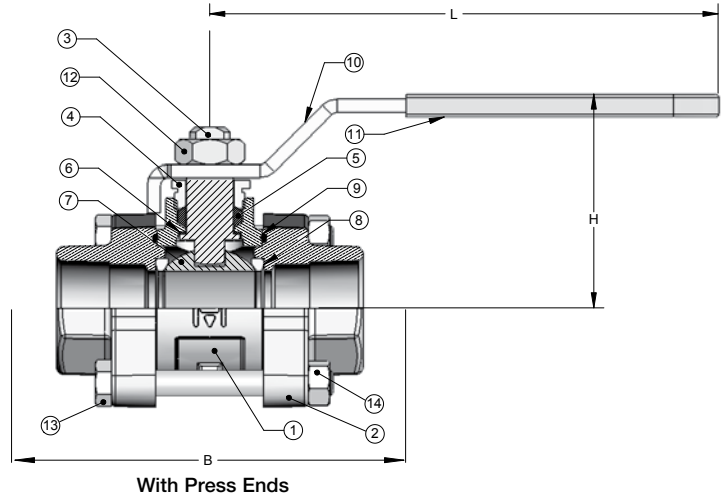

DIMENSIONS

	UNITS	1/2"	3/4"	1"	1-1/4"	1-1/2"	2"
		DN15	DN20	DN25	DN32	DN40	DN50
A (DIA)	INCHES	0.50	0.75	1.00	1.25	1.50	2.00
	mm	13	19	25	32	38	51
STD INSERTION DEPTH	INCHES	0.87	0.98	0.98	1.02	1.42	1.58
	mm	22	25	25	26	36	40
B	INCHES	6.03	7.14	7.82	8.93	9.54	11.9
	mm	153	181	199	227	242	302
H	INCHES	1.85	2.20	2.65	2.79	2.97	3.47
	mm	47	56	67	71	75	88
L	INCHES	4.06	4.58	6.30	6.32	7.20	7.20
	mm	103	116	160	161	183	183
W	INCHES	1.95	2.19	2.48	3.00	3.13	3.78
	mm	50	56	63	76	80	96
F	THREAD SIZE	1/2"	3/4"	1"	1 1/4"	1 1/2"	2"
		NPT	NPT	NPT	NPT	NPT	NPT
Cv	INCHES	17	31	60	110	185	360

Note: DN (Diameter Nominal) = Metric equivalent size.

+Non-Shock

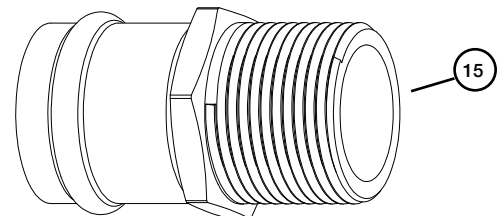
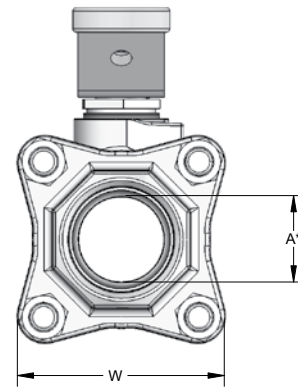

Press End Adapter (4151 SERIES)

The information presented on this sheet is correct at time of publication. Hammond Valve reserves the right to change design and/or materials without notice. For our Installation, Operation and Maintenance Manual and the most current product information go to www.hammondvalve.com. Hammond Valve is a registered trademark of Milwaukee Valve.

⚠ State of California Prop 65 **WARNING:** Cancer and Reproductive Harm. For more information visit www.p65warnings.ca.gov.