



Brass Gate Valve for Potable Water
200 WOG

Threaded Bonnet

Threaded Ends (UP667) • Solder Ends (UP668)

UP667 & UP668 1/4"-2"



MATERIALS LIST

ITEM	PART	MATERIALS	ASTM SPEC.
1	Handwheel Nut	Brass	B16 C36000
2	Nameplate	Aluminum Sheet	Commercial
3	Handwheel	Cast Iron	A48, Class 35
4	Stem	Brass	B283 C27450
5	Packing Nut	Forged Brass	B283 C27450
6	Gland	Brass Rod	B283 C27450
7	Packing Ring	PTFE	Commercial
8	Bonnet	Forged Brass	B283 C27450
9	Locknut	Brass Rod	B283 C27450
10	Wedge	Forged Brass	B283 C27450
11	Body	Forged Brass	B283 C27450

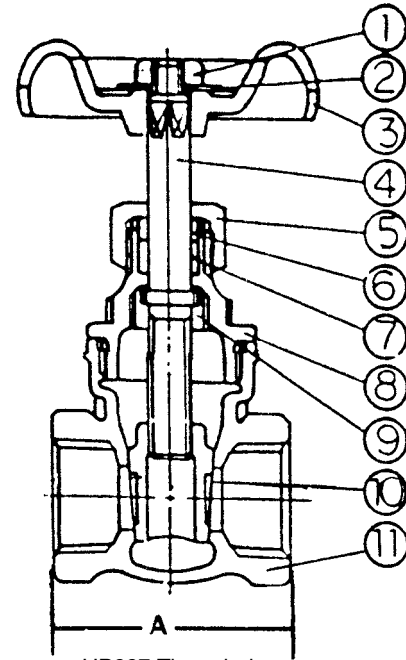

UP667 Threaded

DIMENSIONS

Units	Size	A	B	C	D	Cv
INCHES	1/4	1.63	2.84	2.13	-	5.6
mm		41	72	54		
INCHES	3/8	1.63	2.84	2.13	1.63	10.7
mm		41	72	54	41	
INCHES	1/2	1.69	2.91	2.13	1.78	17.6
mm		43	74	54	45	
INCHES	3/4	1.84	3.31	2.13	2.31	32.0
mm		47	84	54	59	
INCHES	1	2.19	3.94	2.41	2.84	54.0
mm		56	100	61	72	
INCHES	1 1/4	2.42	4.34	2.94	3.00	97.0
mm		61	110	75	76	
INCHES	1 1/2	2.44	4.94	2.94	3.22	135.0
mm		62	125	75	82	
INCHES	2	2.84	6.03	3.19	3.97	230.0
mm		72	153	81	101	

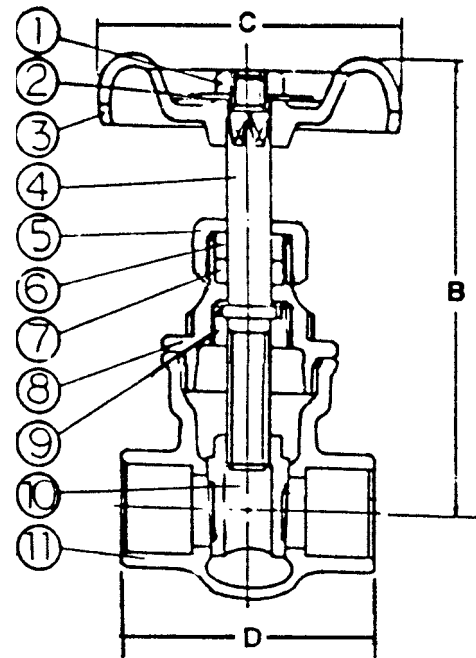

UP668 Solder

Note: Lead free refers to the wetted surface of the pipe, fittings and fixtures in potable water systems that have a weighted average lead content $\leq 0.25\%$. Source: California Health and Safety Code (116875).

The information presented on this sheet is correct at time of publication. Hammond Valve reserves the right to change design and/or materials without notice. For our Installation, Operation and Maintenance Manual and the most current product information go to www.hammondvalve.com. Hammond Valve is a registered trademark of Milwaukee Valve.

⚠ State of California Prop 65 **WARNING:** Cancer and Reproductive Harm. For more information visit www.p65warnings.ca.gov.

