

IB415 1/8"-3/4"

**Bronze Globe Valve
200 SWP - 400 WOG †
Needle Point Bronze Stem
Threaded Bonnet • Threaded Ends
Conforms to: MSS SP-80**

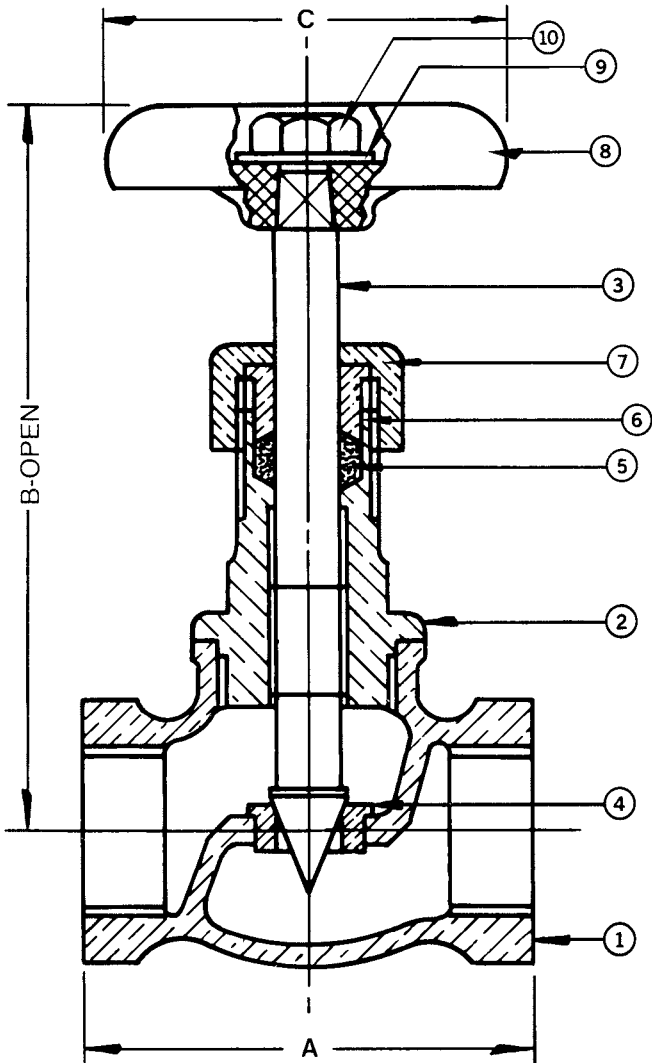

MATERIAL LIST			
No.	PART	MATERIAL	SPECIFICATION
1	Body	Bronze	ASTM B61
2	Bonnet	Bronze	ASTM B61
3	Stem	Bronze	ASTM B61
4	Seat Ring (Pressed In)	Bronze	ASTM B61
5	Packing	Graphite	
6	Gland	Brass	ASTM B 124 C37700
7	Packing	Brass	ASTM B 283 C37700
8	Handwheel	Mall. Iron	Commercial
9	Name Plate	Aluminum	Commercial
10	Handwheel Nut	Brass	Commercial

DIMENSIONS - INCHES/MILLIMETERS				
Units	Size	A	B	C
Inches	1/8	1.63	3.19	2.00
mm		41	81	51
Inches	1/4	1.63	3.19	2.00
mm		41	81	51
Inches	3/8	1.81	3.19	2.00
mm		46	81	51
Inches	1/2	2.31	3.63	2.00
mm		59	92	51
Inches	3/4	2.56	3.94	2.00
mm		65	100	51

† Non-Shock

Note: Not intended for use in potable water.

The information presented on this sheet is correct at time of publication. Hammond Valve reserves the right to change design and/or materials without notice. For our Installation, Operation and Maintenance Manual and the most current product information go to www.hammondvalve.com. Hammond Valve is a registered trademark of Milwaukee Valve.

⚠ State of California Prop 65 **WARNING:** Cancer and Reproductive Harm. For more information visit www.p65warnings.ca.gov.