

IB651 1/4"-3"

Bronze Gate Valve
200 SWP - 400 WOG †
Solid Wedge Disc • Rising Stem
Union Bonnet • Threaded Ends • Stainless Seat
Conforms to: MSS SP-80

Wear-resistant stainless seat rings are securely expanded into the body to assure trouble-free service. Normal seating wear is restricted to the bronze wedge and can be easily replaced.

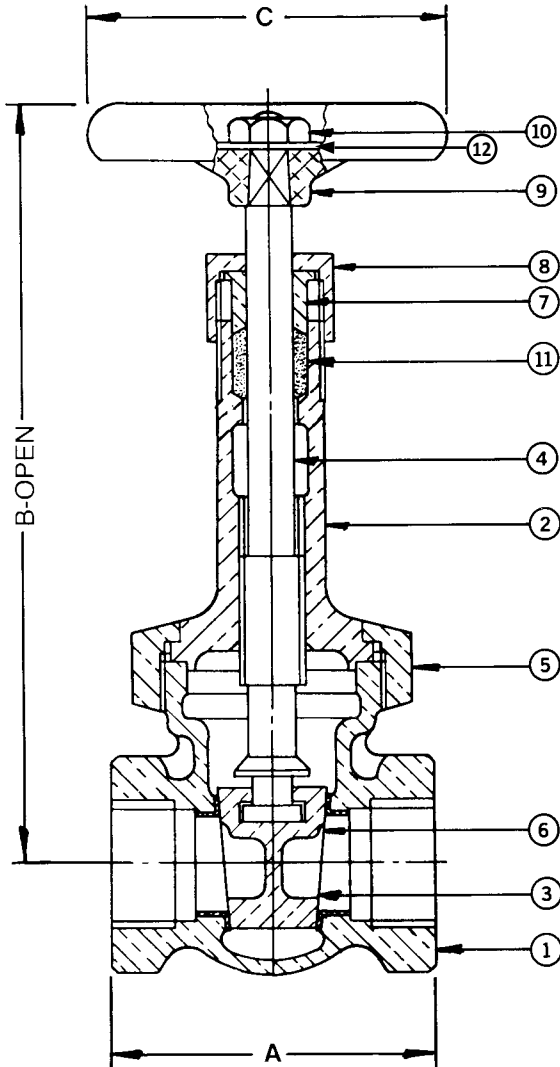

Note: Not intended for use in potable water.

MATERIAL LIST			
No.	PART	MATERIAL	SPECIFICATION
1	Body	Bronze	ASTM B61
2	Bonnet	Bronze	ASTM B61
3	Wedge Disc	Bronze	ASTM B61
4	Stem	Bronze	ASTM B61
5	Union Bonnet Nut	Bronze	ASTM B61
6	Seat Ring	St. Steel	ASTM A 240 TY304
7	Gland	Brass	ASTM B 124 C37700
8	Packing Nut	Brass	ASTM B 283 C37700
9	Handwheel	Mall. Iron	Commercial
10	Handwheel Nut	Brass	Commercial
11	Packing	Graphite	Commercial
12	Identification Plate	Aluminum	Commercial

DIMENSIONS - INCHES/MILLIMETERS					
Units	Size	A	B	C	C _v
Inches mm	1/4	1.81 46	5.13 130	2.00 51	5.6
Inches mm	3/8	1.88 48	5.13 130	2.00 51	10.7
Inches mm	1/2	2.25 57	5.50 140	2.50 64	17.6
Inches mm	3/4	2.50 64	6.25 159	2.75 70	32.0
Inches mm	1	2.88 73	7.19 183	2.75 70	54.0
Inches mm	1 1/4	3.25 83	8.56 218	3.44 87	97.0
Inches mm	1 1/2	3.50 89	9.63 245	3.75 95	135.0
Inches mm	2	3.75 95	11.75 299	4.25 108	230.0
Inches mm	2 1/2	4.63 118	14.50 368	4.75 121	337.0
Inches mm	3	5.00 127	16.75 426	5.50 140	536.0

† Non-Shock

The information presented on this sheet is correct at time of publication. Hammond Valve reserves the right to change design and/or materials without notice. For our Installation, Operation and Maintenance Manual and the most current product information go to www.hammondvalve.com. Hammond Valve is a registered trademark of Milwaukee Valve.

⚠ State of California Prop 65 **WARNING:** Cancer and Reproductive Harm. For more information visit www.p65warnings.ca.gov.