

IB946 1/4"-2"

Bronze Check Valve
150 SWP - 300 WOG †
Horizontal Swing • Threaded Ends
TFE Disc
Conforms to: MSS SP-80

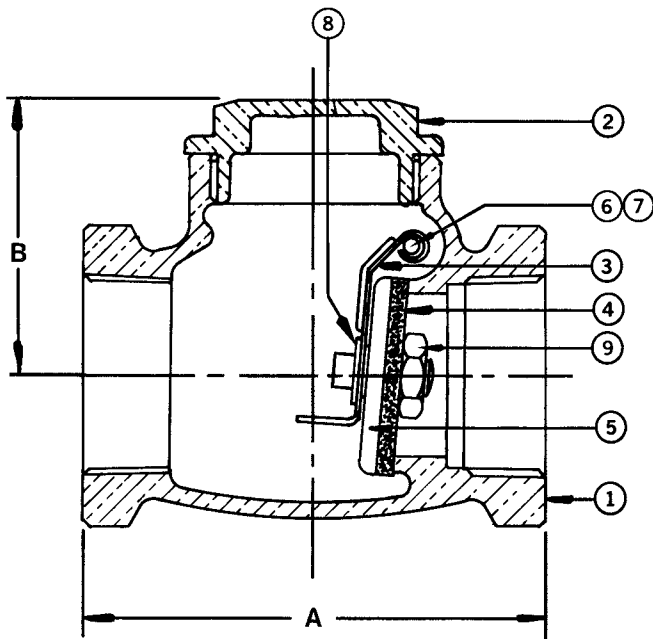

Note: Not intended for use in potable water.

MATERIAL LIST			
No.	PART	MATERIAL	SPECIFICATION
1	Body	Bronze	ASTM B62
2	Cap	Bronze	ASTM B62
3	Lever	Brass	Commercial
4	Disc	TFE	
5	Disc Holder	Brass	ASTM B16 1/4" to 3/4"
		Bronze	ASTM B62 1" to 2"
6	Pin	St. Steel	Commercial
7	Plug (not shown)	Brass	ASTM B16
8	Retaining Ring	St. Steel	Commercial
9	Disc Nut	Brass	ASTM B16

DIMENSIONS - INCHES/MILLIMETERS				
Units	Size	A	B	C _v
Inches mm	1/4	2.13 54	1.32 34	3.3
Inches mm	3/8	2.13 54	1.32 34	6.0
Inches mm	1/2	2.31 59	1.32 34	10.0
Inches mm	3/4	2.63 67	1.69 43	18.0
Inches mm	1	3.25 83	2.00 51	31.0
Inches mm	1 1/4	3.56 91	2.13 54	54.0
Inches mm	1 1/2	4.00 102	2.38 60	76.0
Inches mm	2	4.75 121	2.81 71	131.0

† Non-Shock

The information presented on this sheet is correct at time of publication. Hammond Valve reserves the right to change design and/or materials without notice. For our Installation, Operation and Maintenance Manual and the most current product information go to www.hammondvalve.com. Hammond Valve is a registered trademark of Milwaukee Valve.

⚠ State of California Prop 65 **WARNING:** Cancer and Reproductive Harm. For more information visit www.p65warnings.ca.gov.