

IR322-HI 2 1/2"-6"

Iron Check Valve
250 SWP - 500 WOG †
Horizontal Swing • Flanged Ends
Bolted Cover
Conforms to: MSS SP-71

Flange shape and drilling to specification ASME B 16.1 (250 lb).

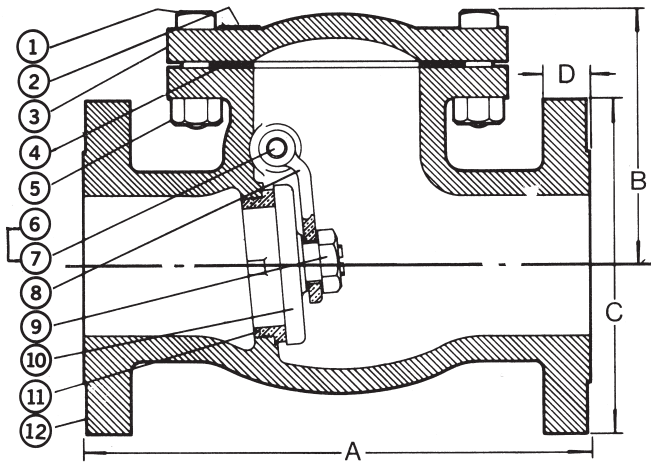

MATERIAL LIST			
No.	PART	MATERIAL	SPECIFICATION
1	Bolt	Steel	
2	Name Plate	Aluminum	
3	Cover	Cast Iron	ASTM A126, Class B
4	Cover Gasket	Graphite	
5	Nut	Steel	
6	Side Plug	Brass	ASTM B16
7	Hanger Pin	Brass	ASTM B16
8	Hanger	Cast Bronze	ASTM B62
9	Disc Nut	Cast Bronze	ASTM B62
10 ¹	Disc	Cast Bronze	ASTM B62
11	Seat Ring	Cast Bronze	ASTM B62
12	Body	Cast Iron	ASTM A126, Class B

¹ 6" discs are cast iron with bronze face rings.

Note 1: On pump discharge, the preferred check valve is an in-line spring loaded swing design with lever and weight. Install these valves as far as possible from the pump and elbows with a minimum distance of 5 times the pipe diameter. See 1400 and 1800 series.

Note 2: These iron body check valves may be installed in both horizontal and vertical lines with upward flow or in any intermediate position.

DIMENSIONS - INCHES/MILLIMETERS						
Units	Size	A	B	C	D	C _v
Inches mm	2 1/2	11.50 292	5.75 146.05	7.50 190.50	1.00 25.40	242
Inches mm	3	12.50 318	6.31 160.35	8.25 209.55	1.13 28.58	366
Inches mm	4	14.00 356	7.56 192.10	10.00 254.00	1.25 31.75	572
Inches mm	6	17.50 445	8.50 215.90	12.50 317.50	1.44 36.53	1287

† Non-Shock

The information presented on this sheet is correct at time of publication. Hammond Valve reserves the right to change design and/or materials without notice. For our Installation, Operation and Maintenance Manual and the most current product information go to www.hammondvalve.com. Hammond Valve is a registered trademark of Milwaukee Valve.

⚠ State of California Prop 65 **WARNING:** Cancer and Reproductive Harm. For more information visit www.p65warnings.ca.gov.