



UP8501/8503 P2* 1/2"-3"

Bronze Ball Valve For Potable Water
Two Piece
Standard Port (1" - 3") Full Port (1/2" - 3/4")
200 psig @ 250°F†
Press x Press Ends
Press x Threaded Ends Available (Consult Factory)
Blow-Out Proof Stem

Dimensions and Workmanship Conform to MSS SP-110

MATERIAL LIST

ITEM	PART	MATERIAL	ASTM SPEC
1	Body	Cast Bronze	B584 C89833
2	Tailpiece	Cast Bronze	B584 C89833
3	Ball	Brass w/Hard Chrome Plating	B283 C27450
		316 Stainless Steel (1)	A276 S31600
4	Seat	RPTFE, 15% Glass filled	
5	Stem	Brass	B21 C46400 H02
		316 Stainless Steel (1)	A276 S31600
6	Thrust Washer	RPTFE, 25% Glass Filled	
7	Packing	PTFE	
8	Packing Nut	Brass	B16 C36000
9	Handle	Steel w/Zinc Plating	Commercial
10	Handle Grip	Vinyl	Commercial
11	Handle Nut	Steel w/Zinc Plating	Commercial
12	Press Adapters	Brass Fitting w/EPDM O-Ring (1/2" - 2")	B283 C27450
		Copper (2 1/2" - 3")	B88
13	O-Ring	EPDM	
14	Backing Seal	Acetal	
15	Backing Ring	304 Stainless Steel	A276

(1) Ball and stem are stainless for UP8503 P2

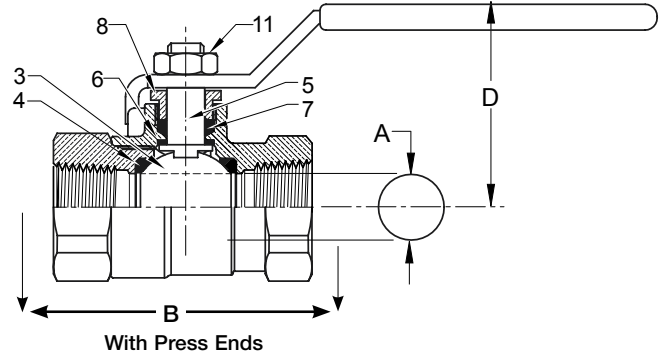

Note: 2 1/2" & 3" are built from UP8511/UP8513 Valve

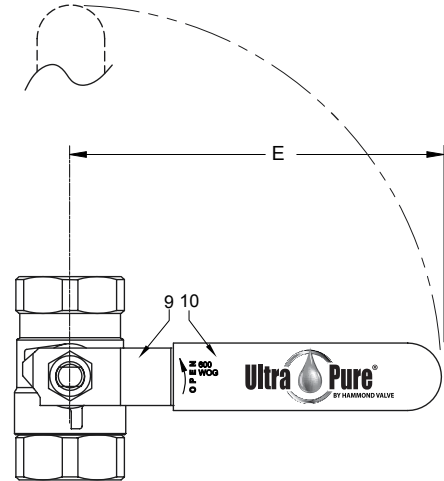

DIMENSIONS

	UNITS	1/2"	3/4"	1"	1-1/4"	1-1/2"	2"	2-1/2"	3"
		DN15	DN20	DN25	DN32	DN40	DN50	DN65	DN80
A (DIA)	INCHES	0.50	0.76	0.88	1.07	1.32	1.57	2.00	2.31
	mm	13	19	22	27	33	40	51	59
STD Insertion	INCHES	0.87	0.98	0.98	1.02	1.42	1.58	1.80	2.10
	mm	22	25	25	26	36	40	46	53
B	INCHES	5.19	6.17	7.17	7.57	8.44	10.30	12.02	13.94
	mm	132	157	182	192	214	262	305	354
D	INCHES	1.91	2.32	2.68	2.82	3.00	3.36	3.47	3.88
	mm	47	59	68	72	76	85	88	99
E	INCHES	3.82	4.55	4.56	6.33	6.33	7.19	7.19	7.19
	mm	94	116	116	161	161	183	183	183

Note: DN (Diameter Nominal)=Metric equivalent size.

†Non-Shock

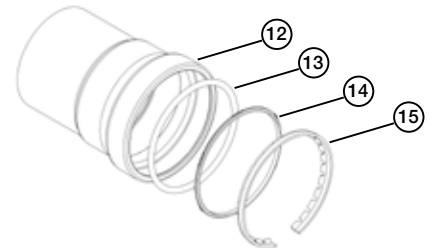
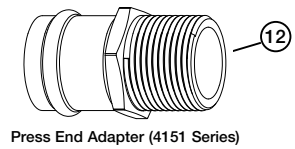

*Both the valve and 4151 series press end adapters are tested and certified by IAPMO R & T to NSF/ANSI 61 and NSF/ANSI 372 for "Lead Free" compliance.

Note: Lead free refers to the wetted surface of the pipe, fittings and fixtures in potable water systems that have a weighted average lead content ≤0.25%. Source: California Health and Safety Code (116875).

The information presented on this sheet is correct at time of publication. Hammond Valve reserves the right to change design and/or materials without notice. For our Installation, Operation and Maintenance Manual and the most current product information go to www.hammondvalve.com. Hammond Valve is a registered trademark of Milwaukee Valve.

⚠ State of California Prop 65 **WARNING:** Cancer and Reproductive Harm. For more information visit www.p65warnings.ca.gov.

